

# SMART ENERGY CONTROLLER

SUN2000-8/10K-LC0



**Active Safety**  
Active Arcing Protection



**Higher Yields**  
Up to 30% More Energy  
with Optimizer



**Battery Ready**  
Plug & Play, Whole-house  
power backup

# Technical Specification

Technical Specification	SUN2000-8K-LCO	SUN2000-10K-LCO
<b>Efficiency</b>		
Max. efficiency		98.1%
European weighted efficiency		97.5%
<b>Input (PV)</b>		
Recommended max. PV power <sup>1</sup>	12,000 Wp	15,000 Wp
Max. input voltage		600 V
Startup voltage		50 V
MPPT operating voltage range		40 ~ 560 V
Rated input voltage		360 V
Max. input current per MPPT		16 A
Max. short-circuit current		20 A
Max. number of inputs		3
Number of MPP trackers		3
<b>Input (DC Battery)</b>		
Compatible battery	LUNA2000-5/10/15-S0	
Operating voltage range	350 ~ 560 Vdc	
Max. operating current	25 A	
Max. charge power	8,000 W	10,000 W
Max. discharge power	8,000 W	10,000 W
<b>Output (On Grid)</b>		
Grid connection	Single-phase	
Rated output power	8,000 W	10,000 W
Max. apparent power	8,800 VA	10,000 VA
Rated output voltage	220 Vac / 230 Vac / 240 Vac, L / N + PE	
Max. output current	40.0 A	45.5 A
Rated AC grid frequency	50 Hz/60 Hz	
Adjustable power factor	0.8 leading ... 0.8 lagging	
Max. total harmonic distortion	≤ 3%	
Backup power output	Yes (via SmartGuard-63A-S0)	
<b>Features &amp; Protection</b>		
Anti-islanding protection	Yes	
DC reverse polarity protection	Yes	
Insulation monitoring	Yes	
DC surge protection	Yes, compatible with TYPE II protection class according to EN/IEC 61643-11	
AC surge protection	Yes, compatible with TYPE II protection class according to EN/IEC 61643-11	
Residual current monitoring unit	Yes	
AC overcurrent protection	Yes	
AC short-circuit protection	Yes	
AC overvoltage protection	Yes	
Over-heat protection	Yes	
Arc fault protection	Yes	
Battery charging from grid	Yes	
<b>General Data</b>		
Operating temperature range	-25°C to +60°C (-13 °F ~ 140 °F)	
Relative operating humidity	0%-100% RH	
Operating altitude	0-4,000 m (Derating above 2,000 m)	
Cooling	Natural convection	Smart Air Cooling
Display	LED indicators; integrated WLAN + FusionSolar app	
Communication	RS485, WLAN / Ethernet via Smart Dongle-WLAN-FE (Optional) 4G / 3G / 2G via Smart Dongle-4G (Optional), EMMA	
Weight	14.5 kg	15 kg
Dimensions (W x H x D) (incl. mounting plate)	425 mm x 376.5 mm x 150 mm	
Degree of protection	IP66	
<b>Optimizer Compatibility</b>		
Compatible optimizer	SUN2000-450W-P2, SUN2000-600W-P	
<b>Standards Compliance (More Available Upon Request)</b>		
Certificates	IEC62109-1, IEC62109-2, EN 61000-6 series , EN 62920 EMC, EN 55011 EMC, ETSI EN 301-489-1 EMC, ETSI EN 301 489-17 EMC, EN 61000 3-11, EN 61000 3-12, IEC61000 2-2	
Grid connection standards	ABNT16149/16150:2013, NRS 097-2-1, PEA, MEA	

\*1.The maximum input voltage is the upper limit of the DC voltage. Any higher input DC voltage would probably damage inverter.

Disclaimer: the preceding values are measured by an internal laboratory of Huawei in a specific environment. The actual values may vary with products, software versions, usage conditions, and environmental factors.

# SUN2000-100KTL-M2 Smart PV Controller



10  
MPP Trackers



98.8% (@480V)  
Max. Efficiency



String-level  
Management



Smart I-V Curve Diagnosis  
Supported



MBUS  
Supported



Support AFCI &  
Smart String Level  
Disconnecter



Surge Arresters for  
DC & AC



IP66  
Protection

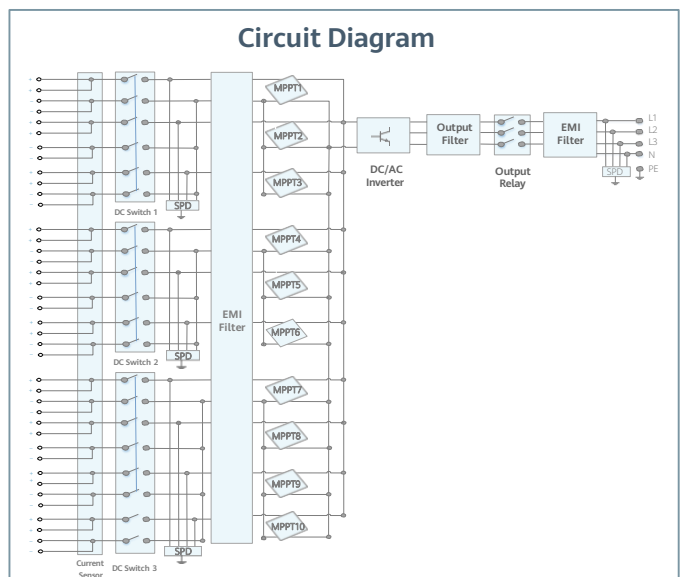
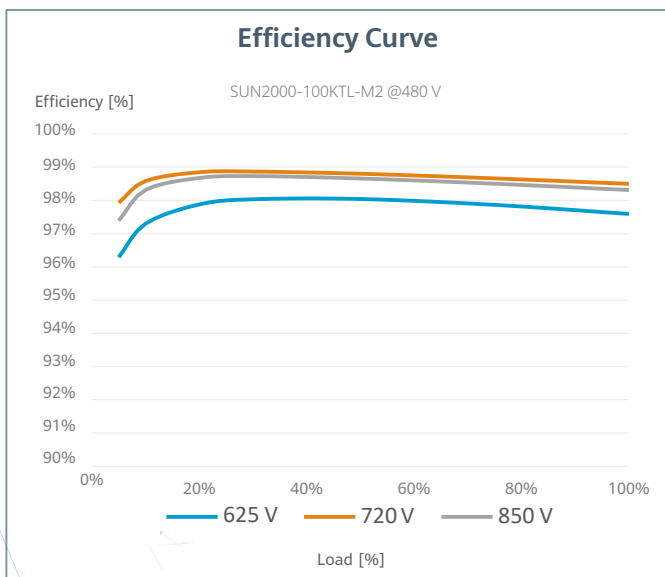

Technical Specification SUN2000-100KTL-M2

Efficiency	
Max. efficiency	98.6% @ 400 V, 98.8% @ 480 V
European efficiency	98.4% @ 400 V, 98.6% @ 480 V

Input	
Max. Input Voltage <sup>1</sup>	1,100 V
Max. Current per MPPT	30 A
Max. Current per Input	20 A
Max. Short Circuit Current per MPPT	40 A
Start Voltage	200 V
MPPT Operating Voltage Range <sup>2</sup>	200 V ~ 1,000 V
Nominal Input Voltage	600 V @ 400 Vac, 720 V @ 480 Vac
Number of MPP trackers	10
Max. input number per MPP tracker	2

Output	
Nominal AC Active Power	100,000 W
Max. AC Apparent Power	110,000 VA
Max. AC Active Power (cosφ=1)	110,000 W
Nominal Output Voltage	400 V / 480 V, 3W+(N)+PE
Rated AC Grid Frequency	50 Hz / 60 Hz
Nominal Output Current	144.4 A @ 400 V, 120.3 A @ 480 V
Max. Output Current	160.4 A @ 400 V, 133.7 A @ 480 V
Adjustable Power Factor Range	0.8 leading... 0.8 lagging
Max. Total Harmonic Distortion	< 3%

Protection	
Input-side Disconnection Device	Yes
Anti-islanding Protection	Yes
AC Overcurrent Protection	Yes
DC Reverse-polarity Protection	Yes
PV-array String Fault Monitoring	Yes
DC Surge Arrester	Type II
AC Surge Arrester	Type II
DC Insulation Resistance Detection	Yes
Residual Current Monitoring Unit	Yes
Arc Fault Protection	Yes
Smart String Level Disconnecter	Yes

Communication	
Display	LED indicators; WLAN adaptor + FusionSolar APP
RS485	Yes
USB	Yes
Smart Dongle-4G	4G / 3G / 2G via Smart Dongle – 4G (Optional)
Monitoring BUS (MBUS)	Yes (isolation transformer required)

General Data	
Dimensions (W x H x D)	1,035 x 700 x 365 mm
Weight (with mounting plate)	93 kg
Operating Temperature Range	-25°C ~ 60°C
Cooling Method	Smart Air Cooling
Max. Operating Altitude	4,000 m (13,123 ft.)
Relative Humidity	0 ~ 100%
DC Connector	Amphenol HH4
AC Connector	Waterproof Connector + OT/DT Terminal
Protection Degree	IP66
Topology	Transformerless
Nighttime Power Consumption	< 3.5 W

Standard Compliance (more available upon request)	
Certificate	EN 62109-1/-2, IEC 62109-1/-2, EN 50530, IEC 62116, IEC 61727, IEC 60068, IEC 61683
Grid Connection Standards	VDE-AR-N4105, EN 50549-1, EN 50549-2, RD 661, RD 1699, C10/11

<sup>\*1</sup> The maximum input voltage is the upper limit of the DC voltage. Any higher input DC voltage would probably damage inverter.

<sup>\*2</sup> Any DC input voltage beyond the operating voltage range may result in inverter improper operating.